

This document contains the proprietary information of Tandemloc, Inc. and your access and use shall be, and is at all times, pursuant to and limited by the Tandemloc, Inc. Terms of Use. You shall not, and shall not encourage, assist, or authorize another party to copy, distribute, publicly display, modify, reverse engineer, decompile, or take any other action to reproduce this document or the information contained herein.

©2019 by Tandemloc, Inc.  
Dimensions are subject to manufacturing tolerance and change.

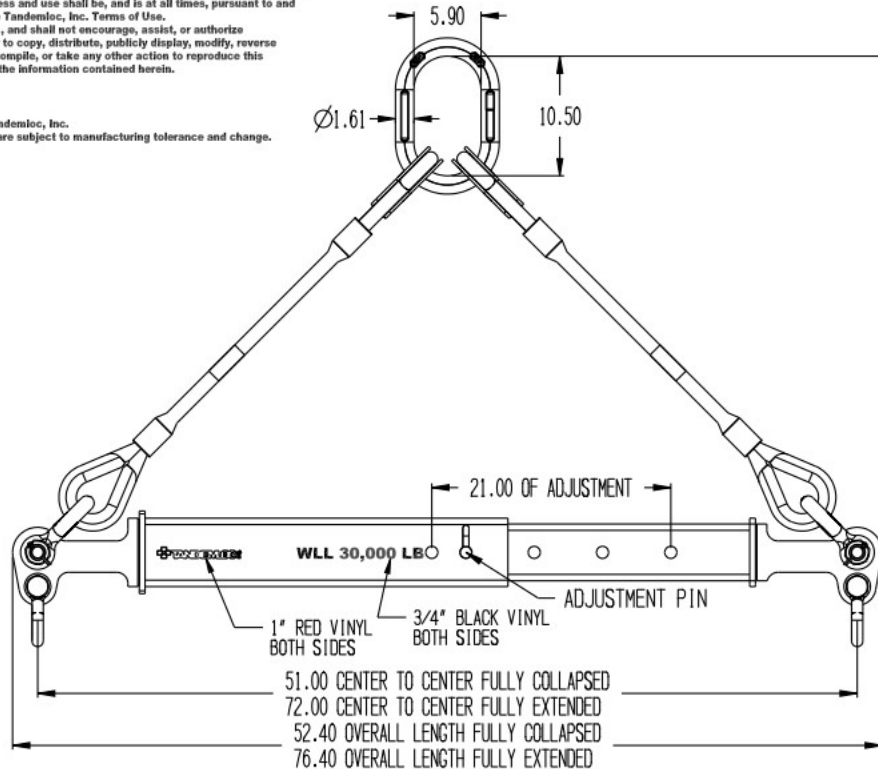

50.84  
PULL TO PULL

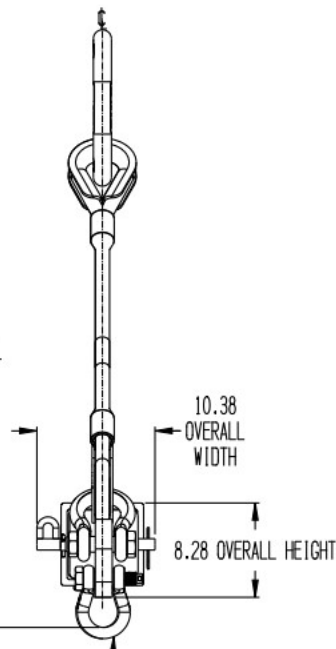

8.5 TON SHACKLES  
TYP., 2 PLACES  
ON BOTTOM

- NOTES:
- PART NO.: AT14A030-072-PA, 51"-72" TELESCOPIC SPREADER  
AT14A030-072SPA, 51"-72" TELESCOPIC SPREADER WITH TOP SLING
  - WLL: 30,000 LB. @ 45° MINIMUM
  - PROOF TESTED TO 125% (37,500 LB.) AND CERTIFIED
  - STANDARD SPECIFICATION # EAD21000A APPLIES
  - FINISH: SANDBLAST AND PRIME AND PAINT YELLOW
  - CALCULATED WEIGHT: 220 LB. SPREADER WITH SLING: 287 LB.
  - DESIGNED AND MANUFACTURED TO MEET OR EXCEED ASME B30.20 AND BTH-1, DESIGN CATEGORY B, SERVICE CLASS 0.

\*\* DO NOT SIGN IF CHANGES ARE REQUIRED \*\*  
CUSTOMER APPROVAL: \_\_\_\_\_  
DATE: \_\_\_\_\_

<small>1 1/2" DIMENSIONS APPLICABLE UNLESS OTHERWISE NOTED. DIMENSIONS ARE IN INCHES &amp; TOLERANCES ARE: - XX ±.05, XXX ±.005, .XXX ±.01</small>		<small>1" DIMENSIONS APPLICABLE UNLESS MAX. CLOSING TEL. IS: 0 TO 4" ±.03, 4.01" TO 7" ±.02, 7.01" TO 10.5" ±.02, OVER 10.5" ±.02</small>		
<small>THIS DOCUMENT CONTAINS PROPRIETARY INFORMATION. IT IS THE PROPERTY OF TANDEMLOC, INC. REPRODUCING OR DISTRIBUTING THIS DOCUMENT WITHOUT THE WRITTEN APPROVAL OF TANDEMLOC, INC. IS EXPRESSLY PROHIBITED.</small>		<small>APPROVALS</small> <small>DATE</small> <small>01-14-19</small>		
<small>REV</small> <small>DATE</small> <small>01-14-19</small>		<small>REV</small> <small>DATE</small> <small>01-14-19</small>		<small>REV</small> <b>D</b>
<small>SCALE</small>		<small>SCALE</small>		<small>REV</small> <b>SAT14A030-072-PA</b>